

## Exemple de proiectari instalatii solare

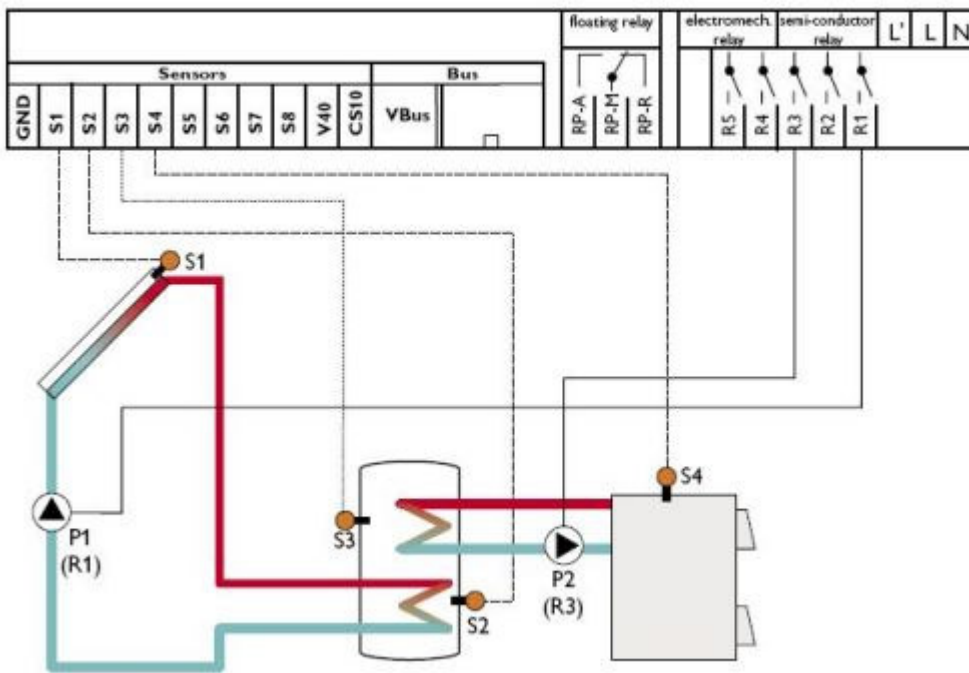

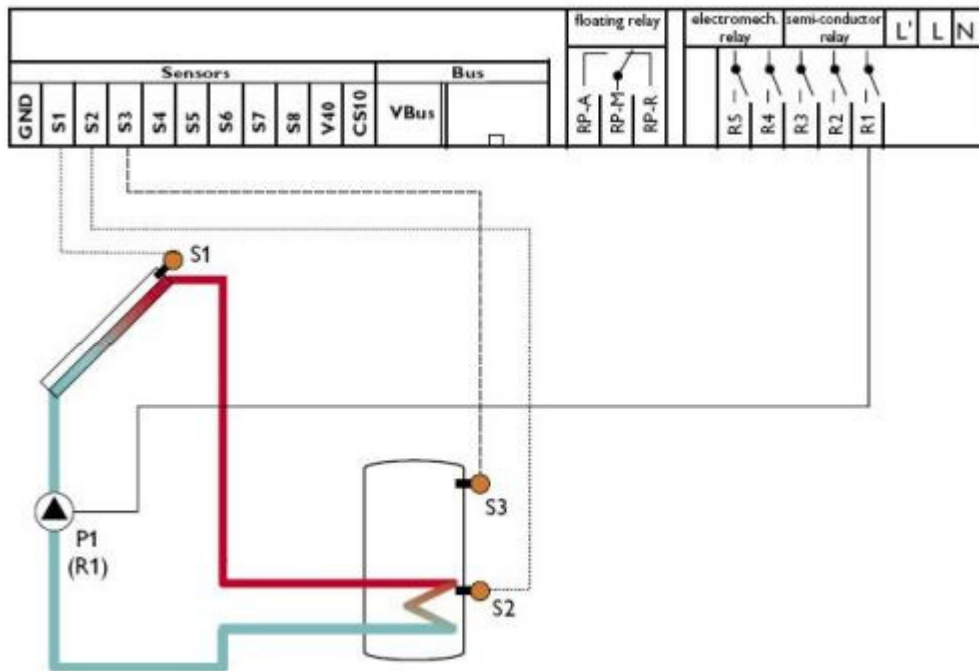

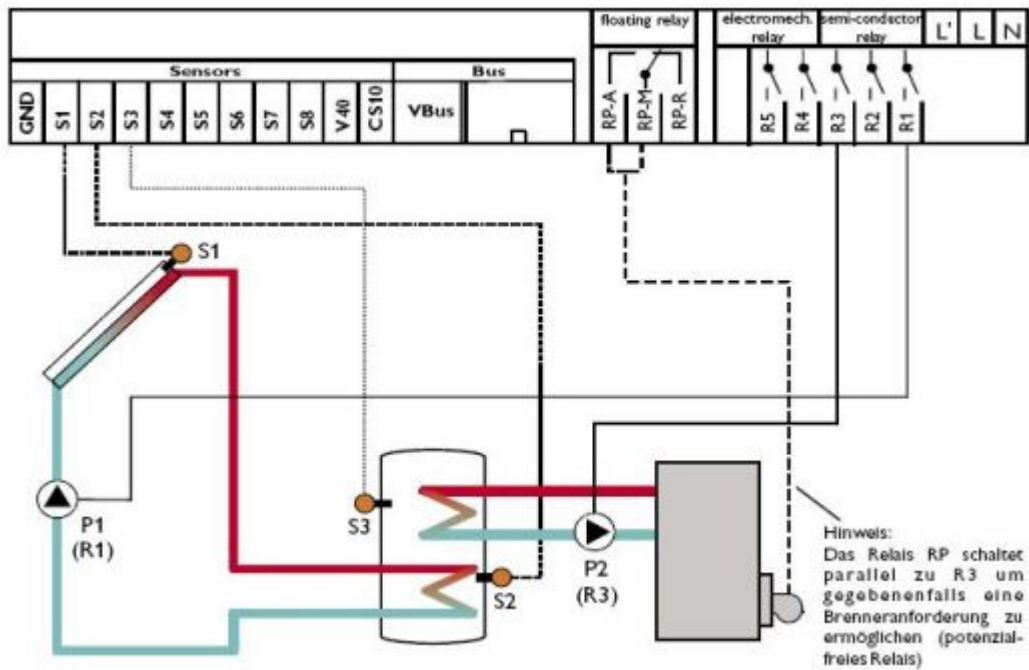

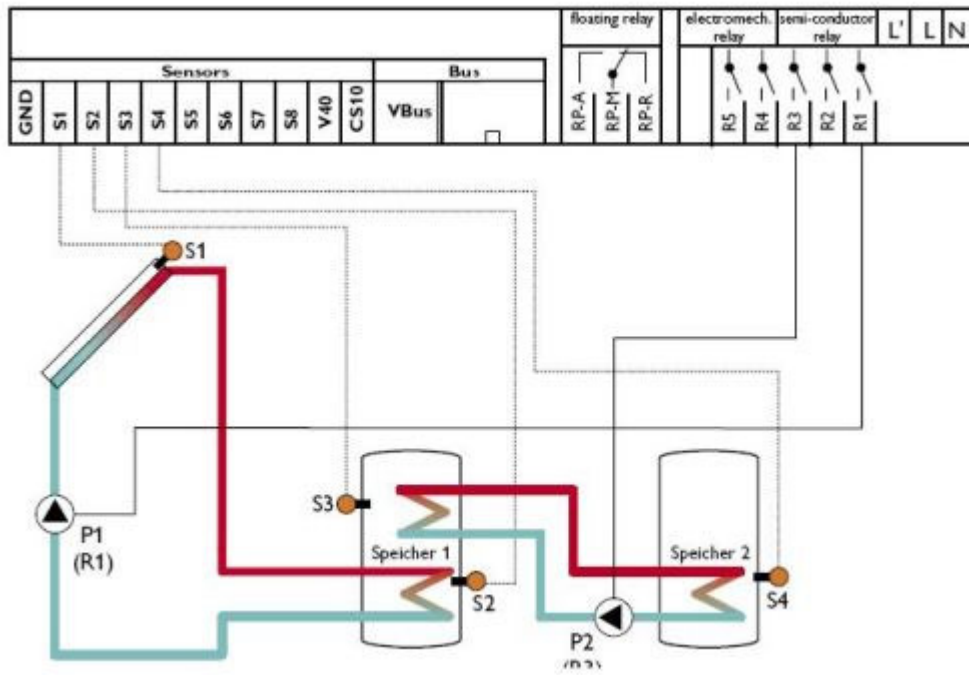
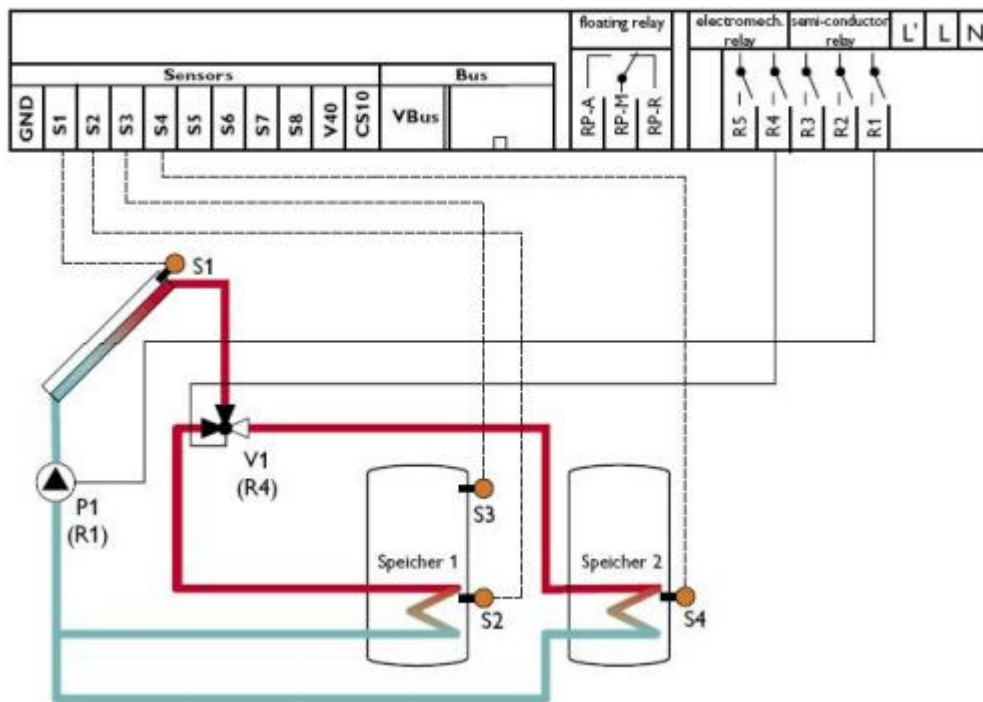
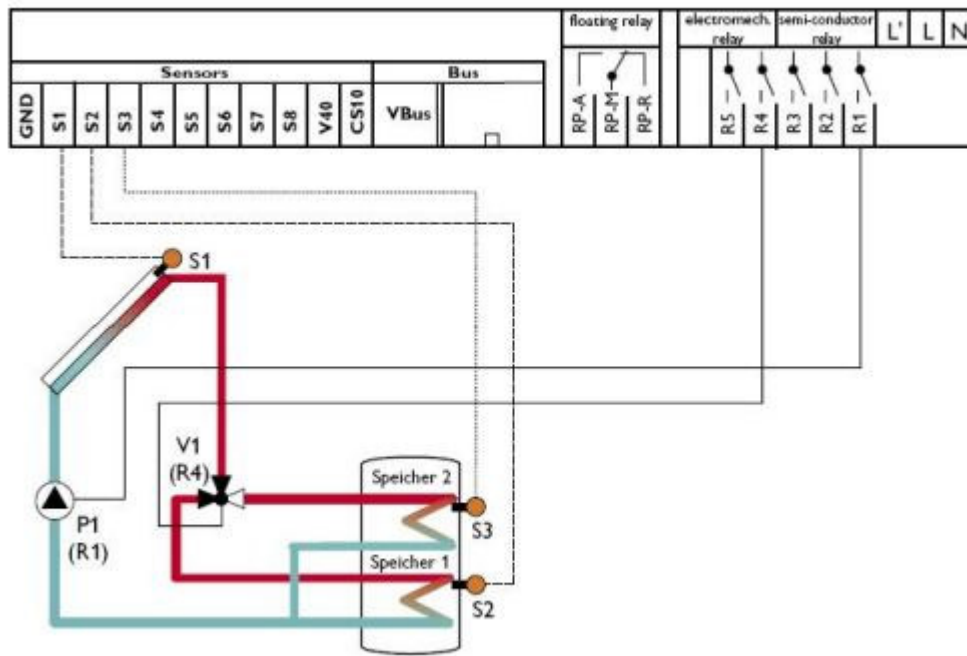
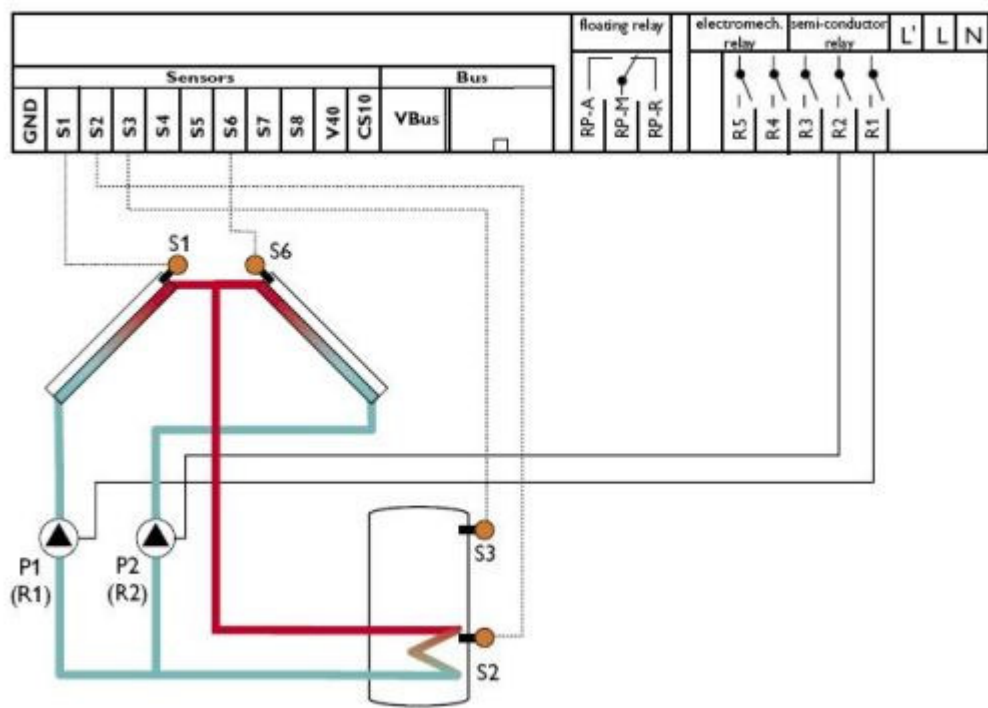
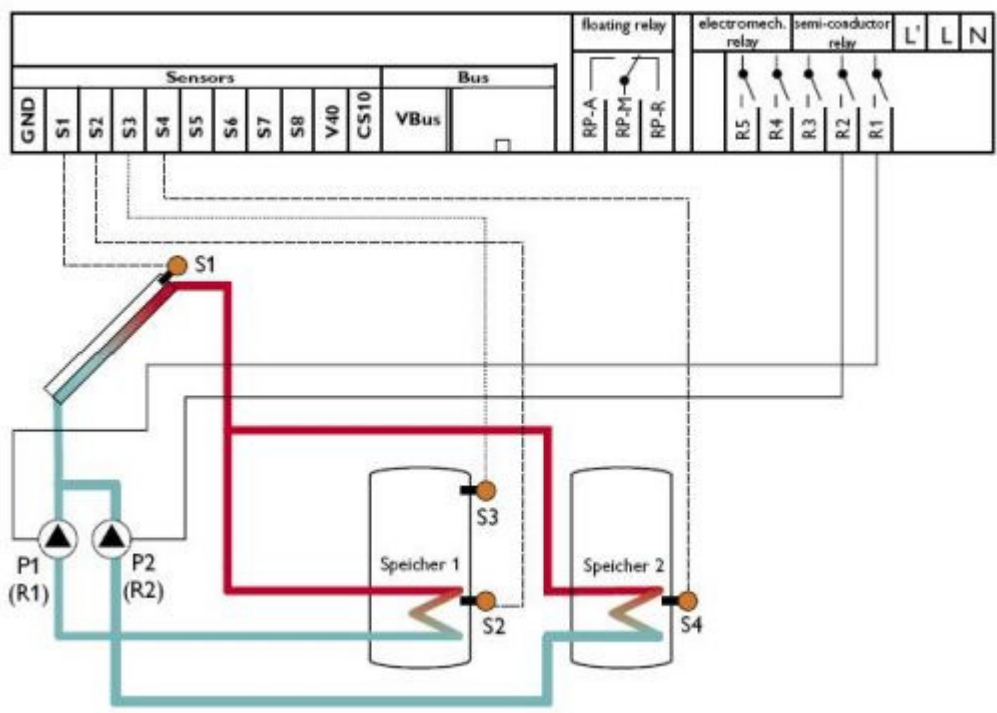

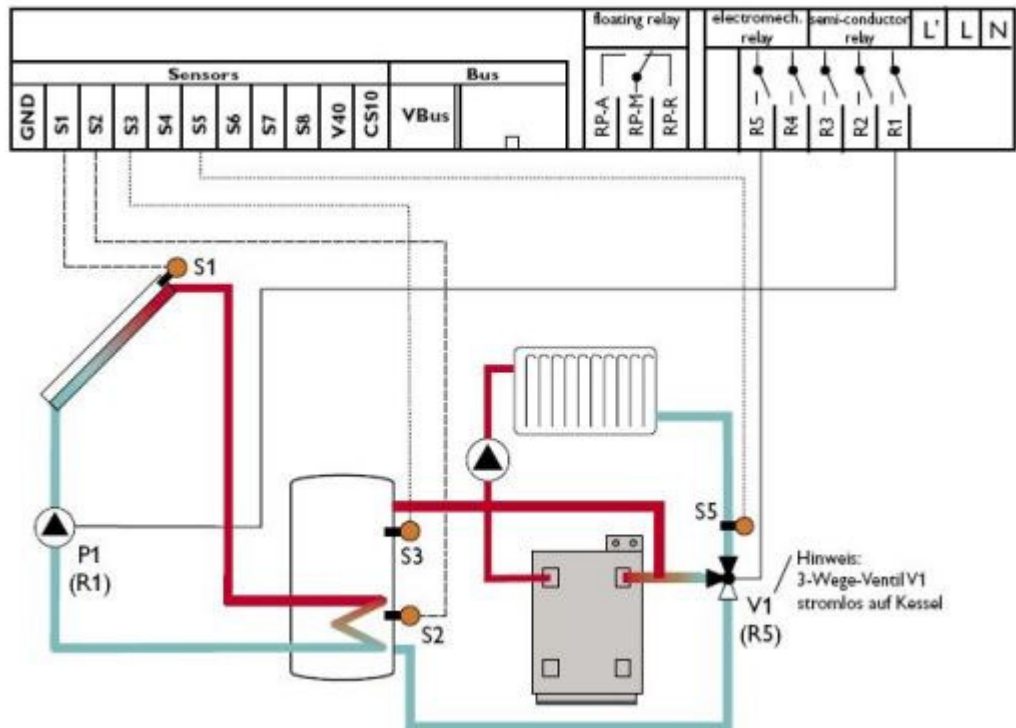
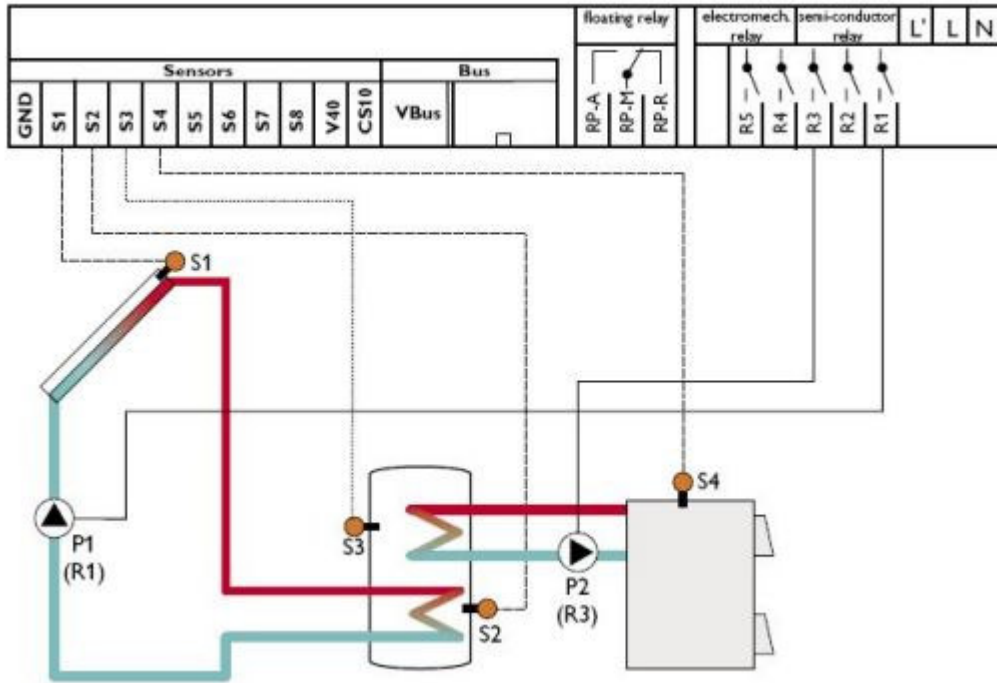

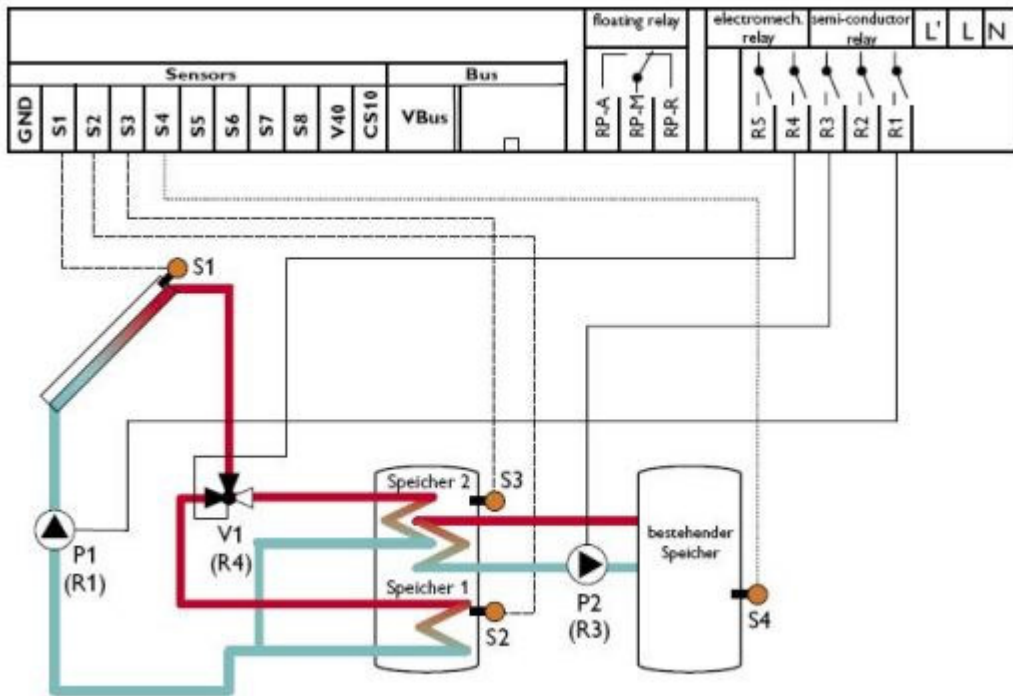
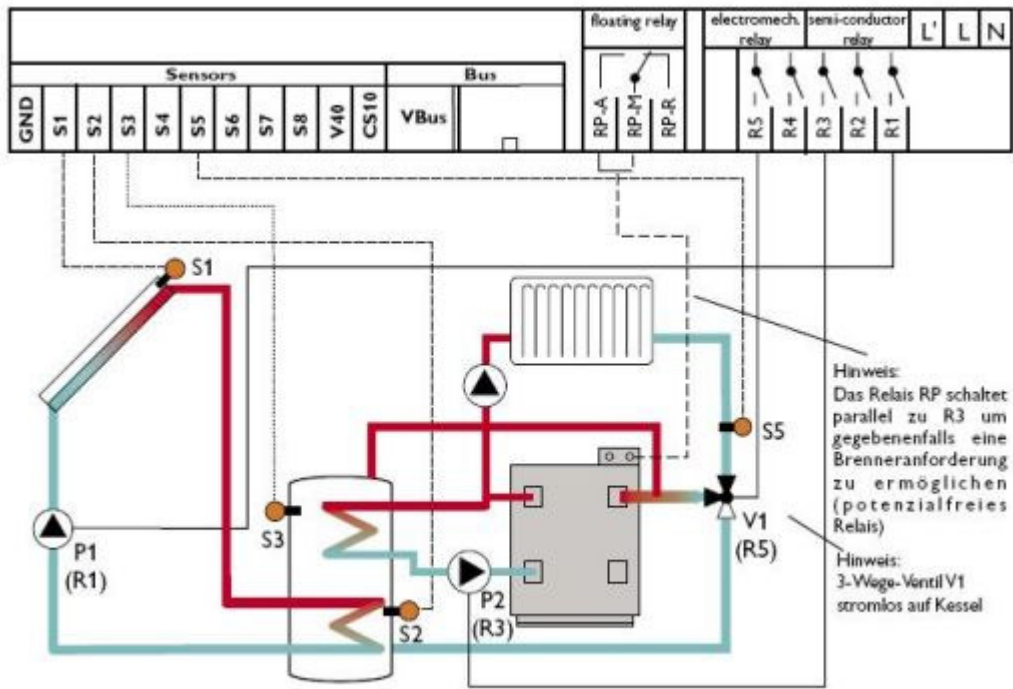

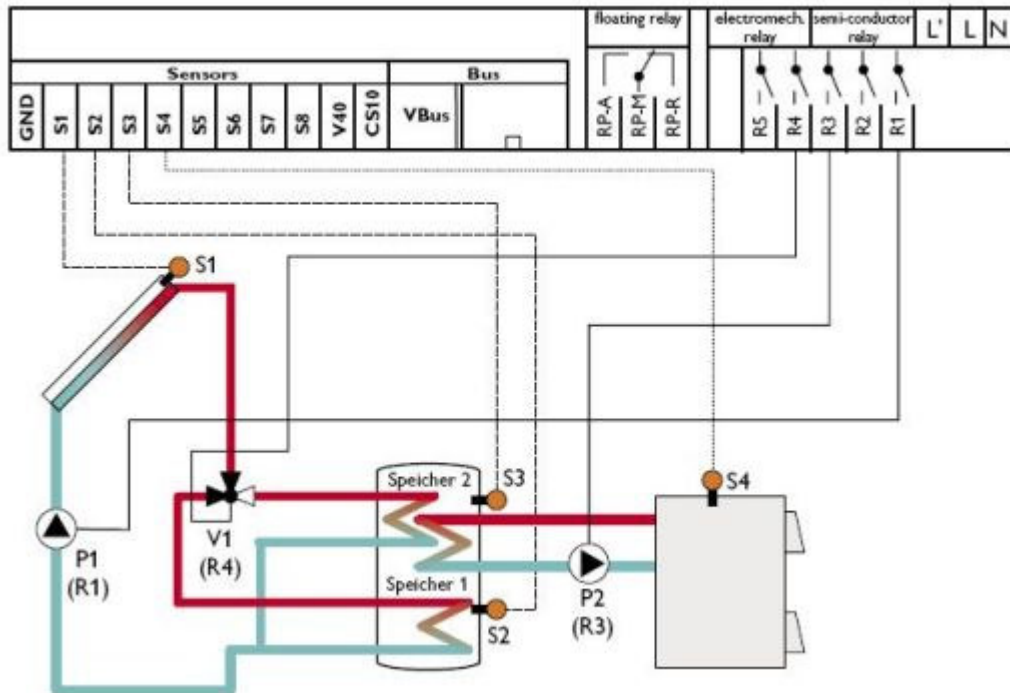
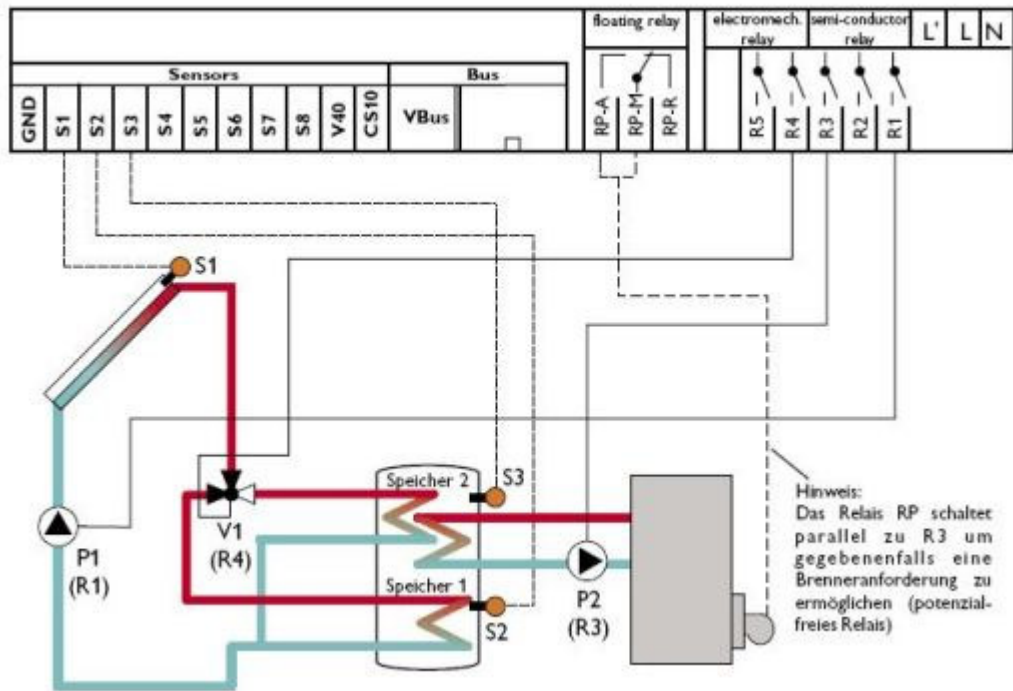

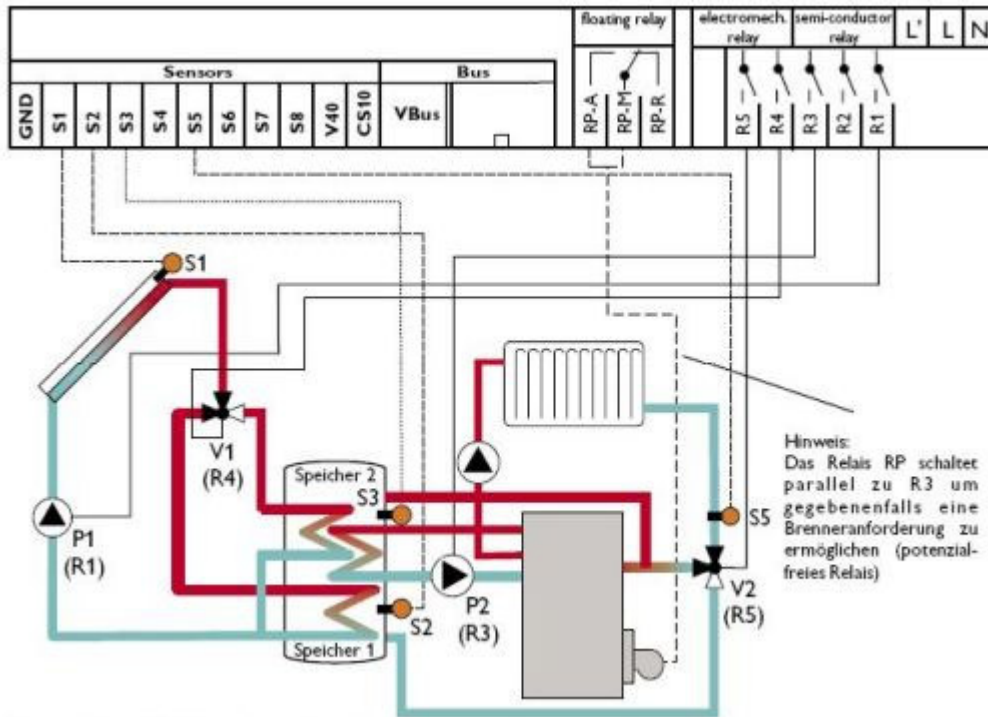
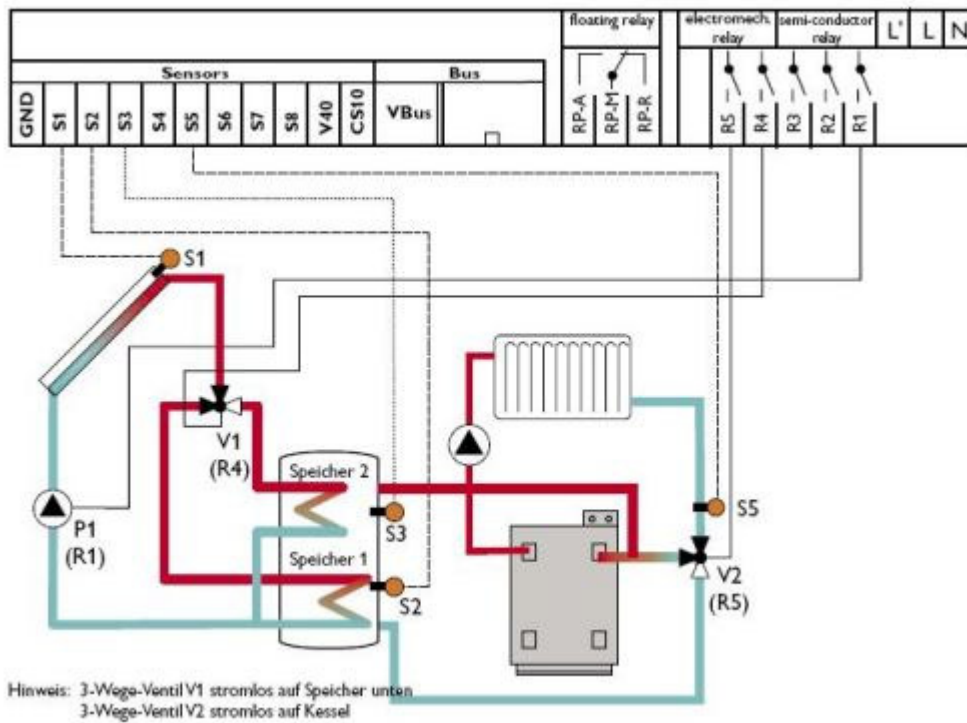

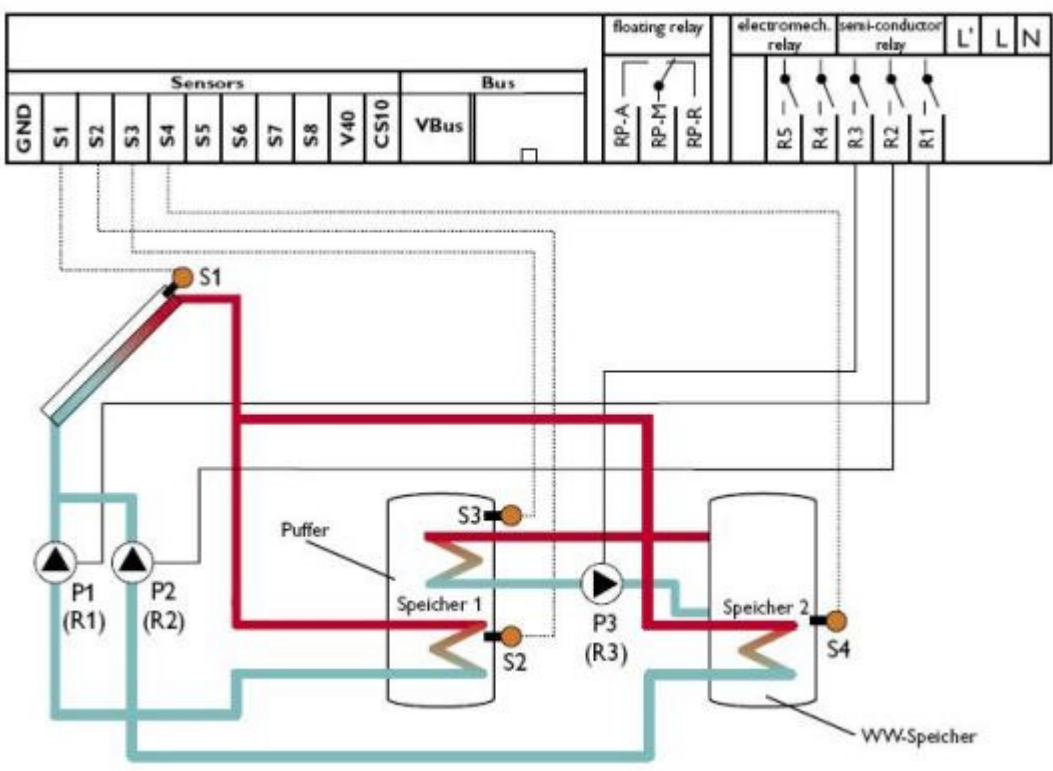
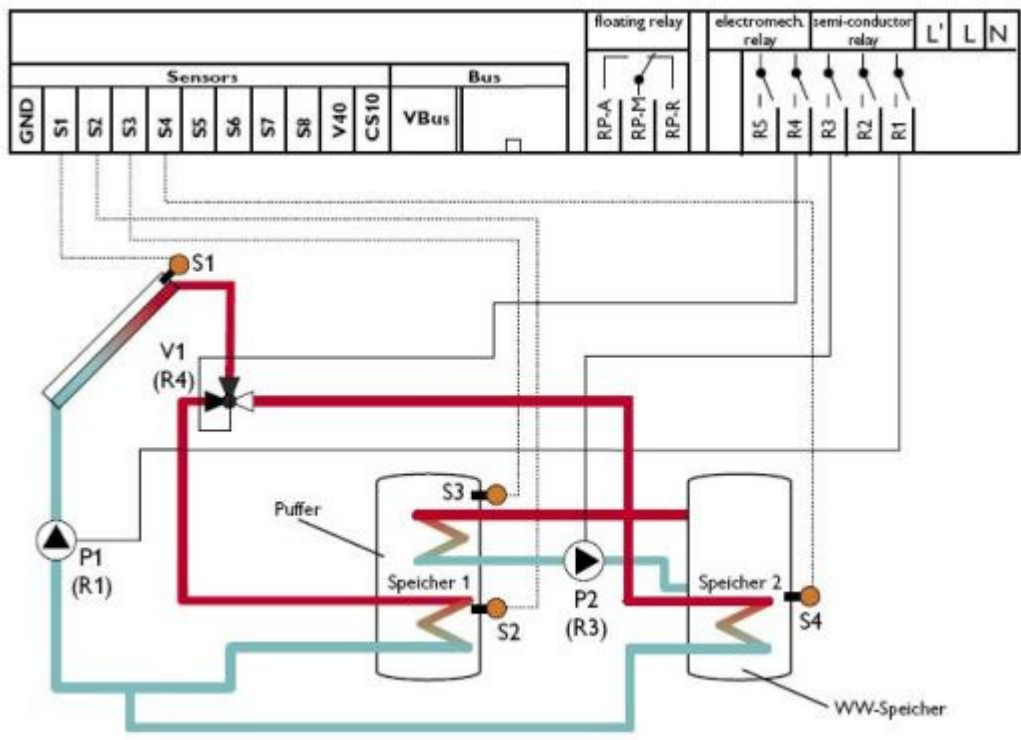

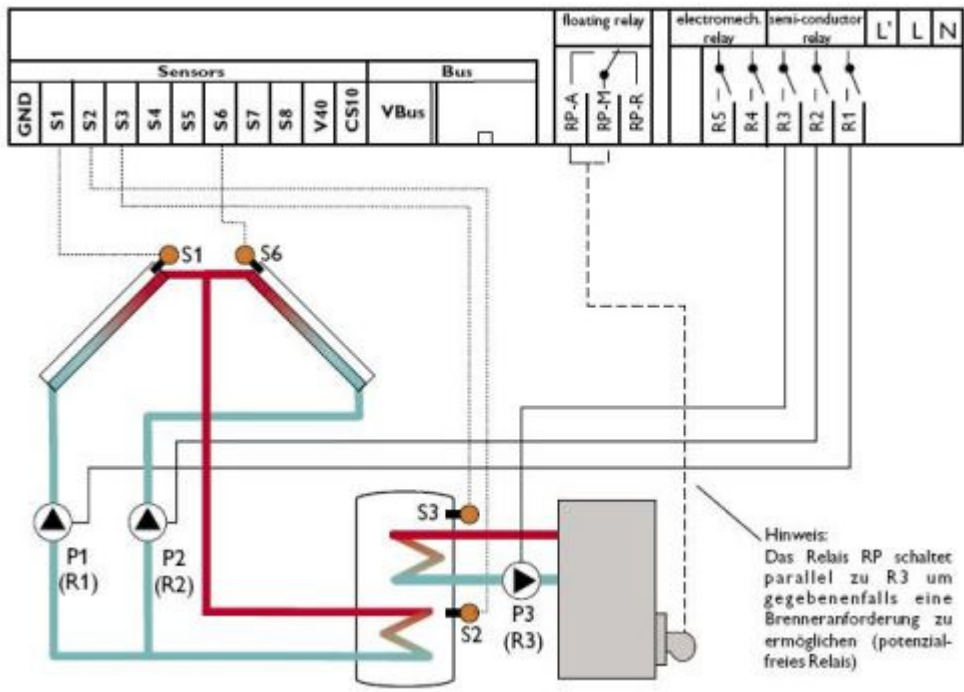
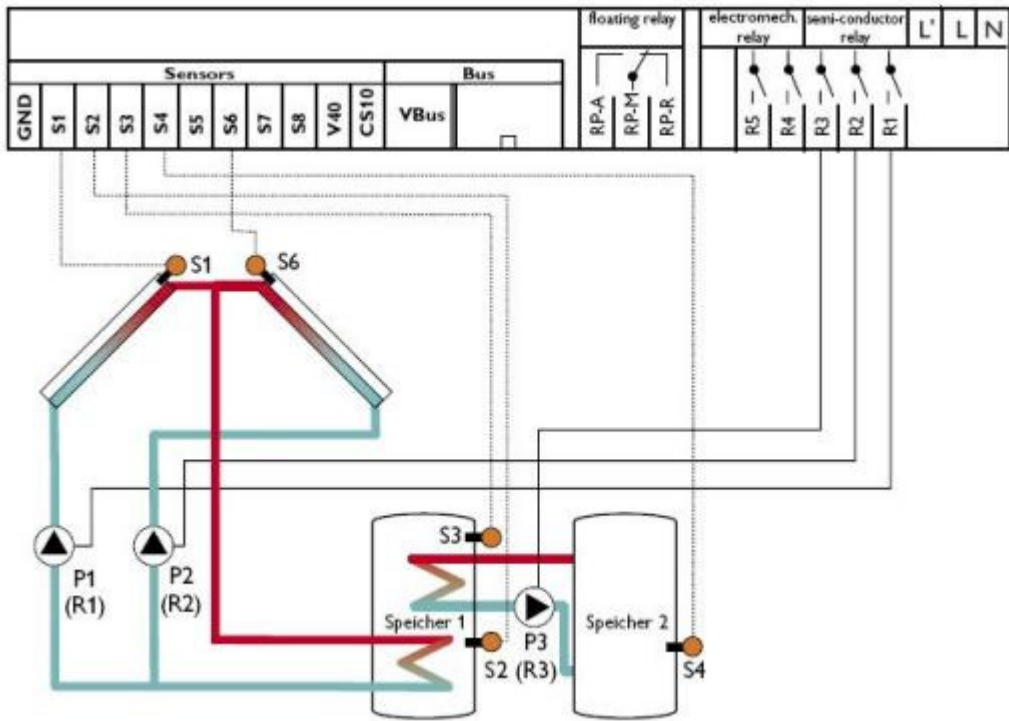

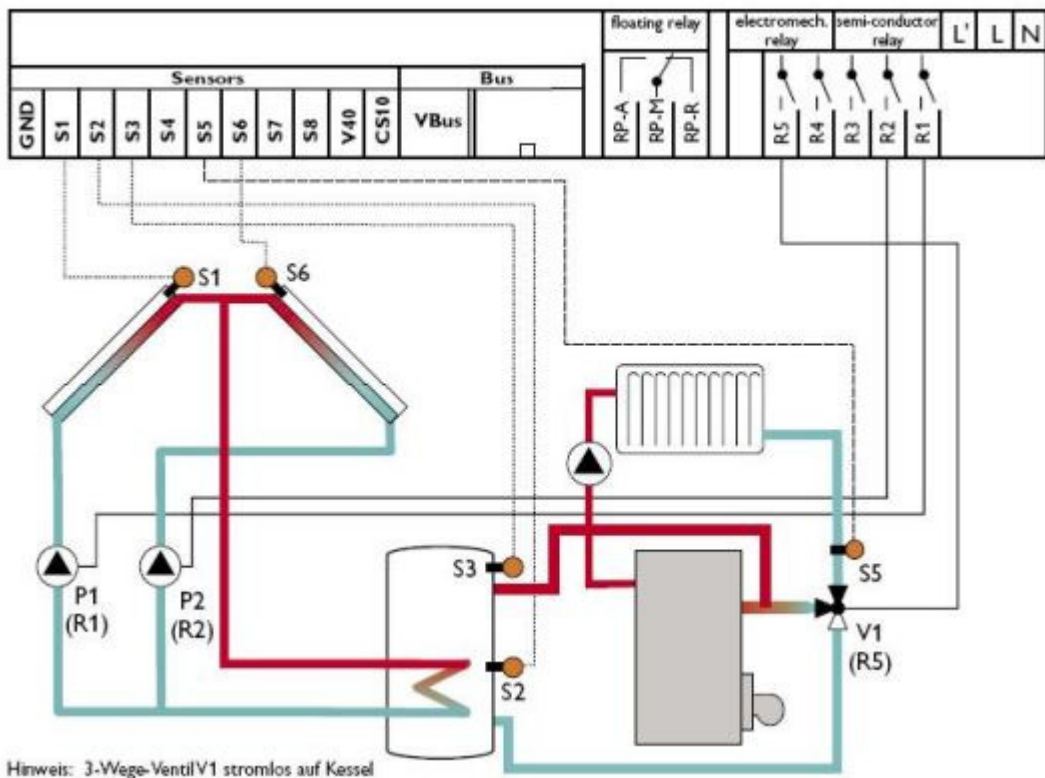
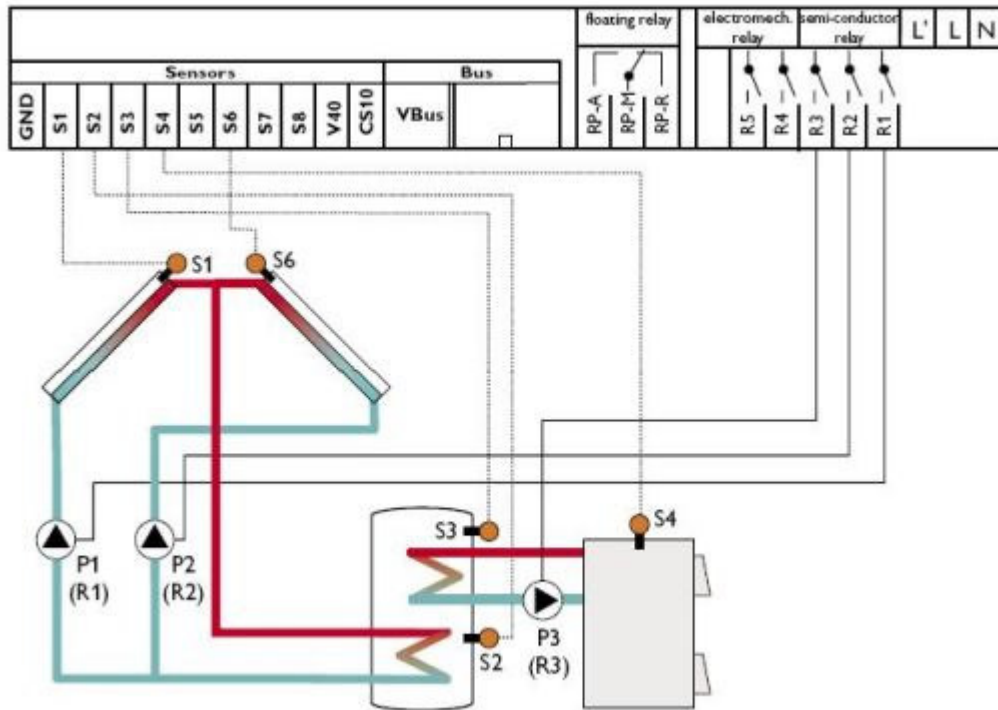

Hinweis: 3-Wege-Ventil V1 stromlos auf Kessel

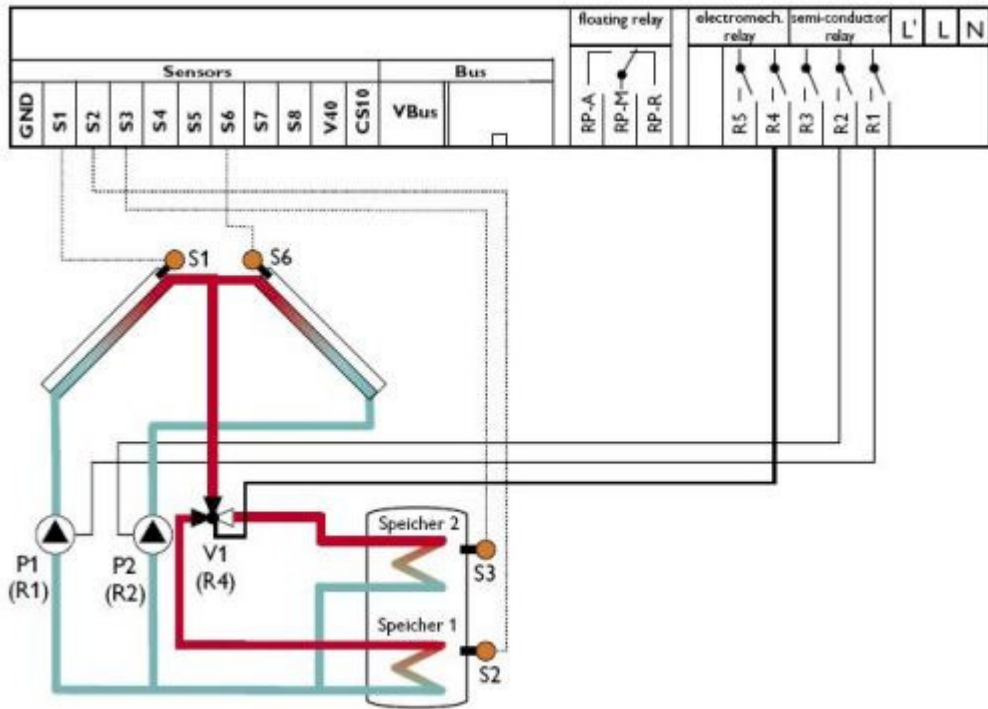
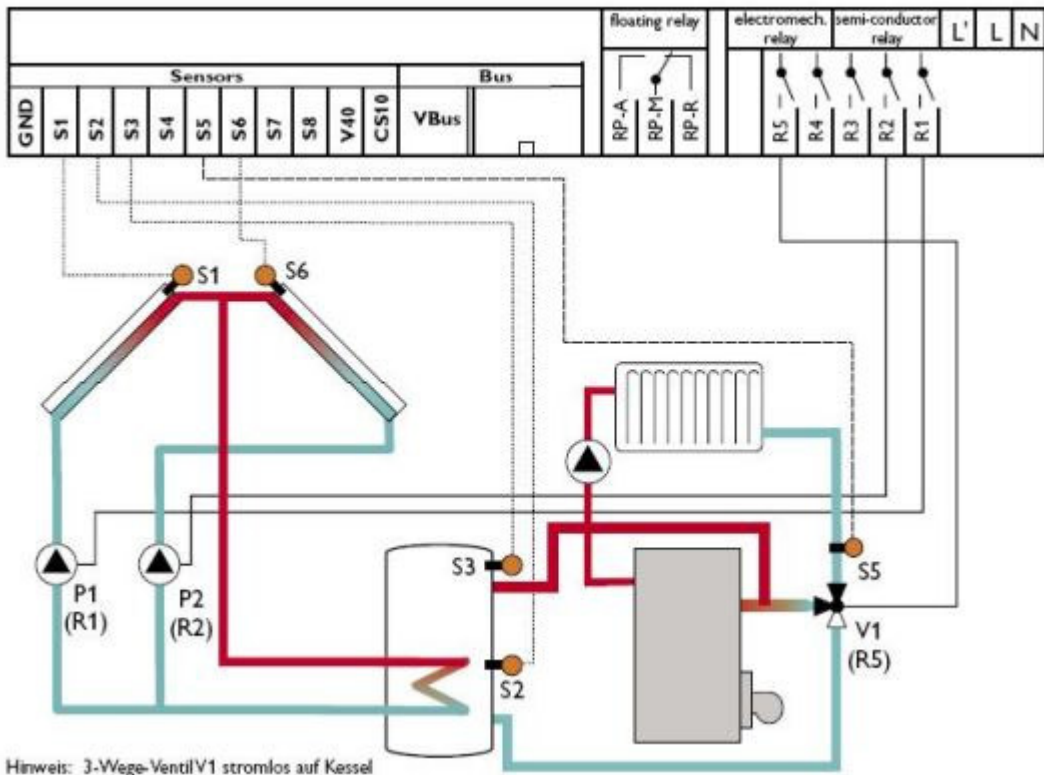

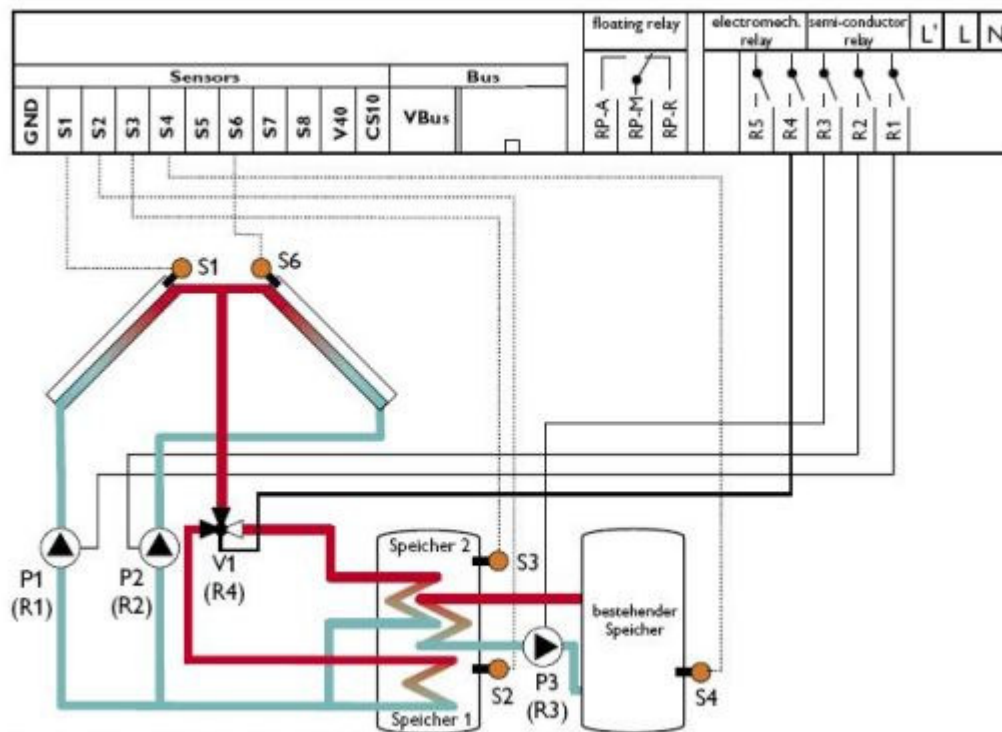

Hinweis: 3-Wege-Ventil V1 stromlos auf Speicher unten

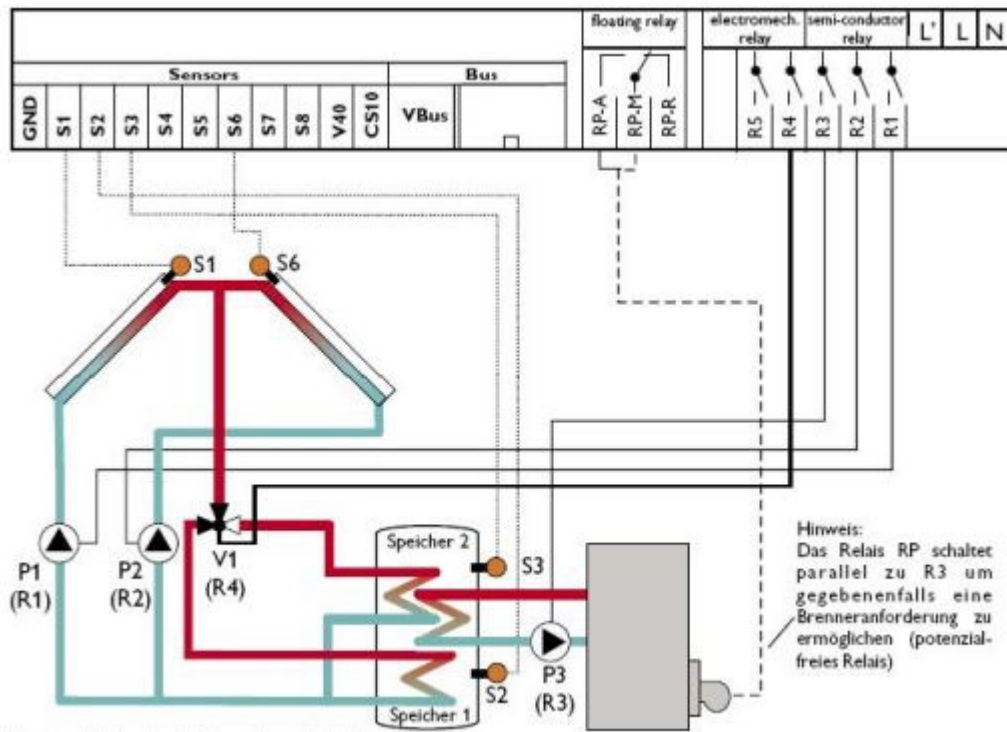

Hinweis:  
Das Relais RP schaltet  
parallel zu R3 um  
gegebenenfalls eine  
Brenneranforderung zu  
ermöglichen (potenzial-  
freies Relais)

Hinweis: 3-Wege-Ventil V1 stromlos auf Speicher unten

